

the potted plant tango

i. french

♩=170, sultry samba

A

clarinet in bb

trumpet in bb

tuba

drum set

castanets/
finger clicks

misc. percussion

piano

♩=170, sultry samba

try and sound as close to a classical guitar as possible

A

lead guitar

rhythm guitar

ukulele

electric bass

voice

i wish that i could tan-go but i sad-ly can't, 'cuz there are no tan gos for_ pot-ted plants,

10

B %

cl. *mp* *ff* *mp* *f*

tpt. *mp* *ff* *mp* *f*

tba. *mp* *ff* *mp* *f*

dr. *ff* *mp*

cost. *mf* *ff* *mp*
second time only

perc.

prn. *ff* *mp*

E7 Am Dm E7 Am E7 Am Dm

I. gtr. *mp*

r. gtr. *mf* *ff* *mp*

uke. *mf* *ff* *mp*

bass *ff* *mf*

vox
i can-not ev - en o - pen a door yet a - lone find my love on the dance - floor
i see my own - er watch tan - gos on their li - ttle screen, i see

the potted plant tango

19

C

cl. *mp* *f* *f* *mf*

tpt. *mp* *f* *f* *mf*

tba. *mp* *f* *ff* *mf*

dr. 4 2

cast. 4 2

perc. 4 To Perc. *mf* vox (unpitched): oh why!

pno. *mf*

C

i. gtr. *f*

r. gtr. G C E7 Am Dm E7 E7 Am

uke. G C E7 Am Dm E7 E7 Am

bass E7 follow rhythm pattern, use the chords for note choice Am

vox *mf*

beau-ti-ful wo-men and men that are lean, they move with such grace, and sway to and fro, as they el-e-gant-ly dance the tan-go, "oh why?" i scream up to the sky my leaves will not

the potted plant tango

To Coda ◊

cl. 

tpt. 

tba. 

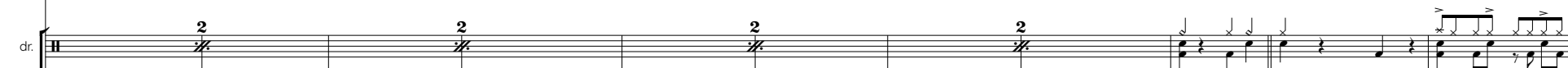
dr. 

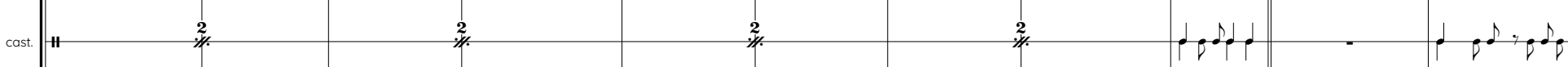
cast. 

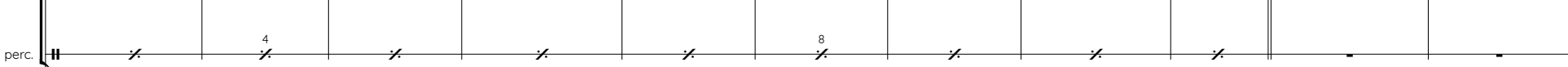
perc. 

pno. 

To Coda ◊

l. gtr. 

r. gtr. 

uke. 

bass 

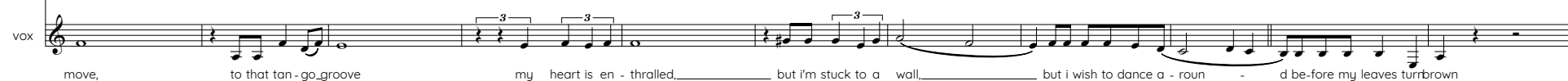
vox 

move, to that tan-go groove my heart is en-thrall- but i'm stuck to a wall, but i wish to dance a- round be-fore my leaves turrbrown

40 **D** *ad lib solo or solo as written* *f* *Am* *Dm* *Am* *E7* *the potted plant tango*

cl. *f*

tpt. *sfz*

tba. *sfz* *p*

dr. *mp* **2** **2** **2** **2**

cast. *mp* **4** **8**

perc.

pno. *sfz* *sfz*

l. gtr. **D** *sfz*

r. gtr. *E7* *Am* *Dm* *Am* *E7* *p*

uke. *E7* *Am* *Dm* *Am* *E7* *p*

bass *sfz*

Detailed description of the musical score: This is a page of a musical score for a piece titled 'the potted plant tango'. The score is for a full band and includes parts for Clarinet (cl.), Trumpet (tpt.), Trombone (tba.), Drums (dr.), Castanets (cast.), Percussion (perc.), Piano (pno.), Left Guitar (l. gtr.), Right Guitar (r. gtr.), Ukulele (uke.), and Bass. The music is in 4/4 time and features a complex harmonic structure with frequent chord changes. The key signature has one flat (B-flat major or D minor). The score begins at measure 40. The Clarinet part starts with a forte (f) dynamic and a melodic line. The Trumpet and Trombone parts have a fortissimo (sfz) dynamic. The Drums play a steady rhythm with a dynamic of mezzo-piano (mp). The Castanets play a rhythmic pattern with a dynamic of mezzo-piano (mp). The Piano part has a fortissimo (sfz) dynamic. The Guitars and Ukulele parts have a piano (p) dynamic. The Bass part has a fortissimo (sfz) dynamic. The score includes various musical notations such as slurs, accents, and dynamic markings. There are also some performance instructions like 'ad lib solo or solo as written'. The page number 5 is in the top right corner.

the potted plant tango

Am B7 E7/B E7/A E7/G#

E
E7 go wild! (triple improv with trumpet and guitar) Am Dm

f

E7 go wild! (triple improv with clarinet and guitar) Am Dm

f

mf

feel free to make this as funky as possible

2 2 4 2

cast. 12 4

perc. start here! 4

f

E
E7 go wild! (triple improv with trumpet and clarinet) Am Dm

f

Am B7 E7/B E7/A E7/G# E7 Am Dm

Am B7 E7/B E7/A E7/G# E7 Am Dm

feel free to elaborate and improv

E7 Am Dm

f

the potted plant tango

63 Am E7 Am B7 **F**

cl. Am E7 Am B7

tpt. Am E7 Am B7

tba. Am E7 Am B7

dr. 2 2 2 2

cast. 8 12

perc. 8 12

pno.

l. gtr. Am E7 Am B7 **F**

r. gtr. Am E7 Am B7

uke. Am E7 Am B7

bass Am E7 Am B7

D.S. al Coda

73
cl.

tpt.

tba.

dr.

cast.

perc.

pno.

l. gtr.

r. gtr.

uke.

bass

vox

D.S. al Coda

i see my

d be-fore my leaves turn be-fore my leaves turn be-fore my leaves turn brown!